

Installation & Wiring Instructions

T2N/1S High Voltage DALI-2 Self-test Emergency Conversion Kit

PLEASE READ THESE INSTRUCTIONS BEFORE COMMENCING INSTALLATION & LEAVE WITH END USER

Description:

The Liteplan range of T2N/1S modules are designed to convert a wide range of high voltage LED types. The T2N/1S will convert most standard LED luminaires and arrays between 50V and 300V. This makes the T2N/1S suitable for linear luminaires, high voltage boards and even some mains voltage lamps (subject to testing). The modules are designed to generally be installed by breaking into the DC voltage connection between the mains driver and the LEDs and allows the LEDs to be operated as normal under mains healthy conditions and operated at reduced light output in an emergency.

The module automatically adjusts the output LED current to provide the best match between the battery and the load, providing maximum illumination whilst ensuring full battery duration and are compatible with a wide range of lighting. The unit will recharge the batteries after the test of clause 22.3 of BS EN 61347-2-7:2012.

The battery is fitted with a PCM to protect the supply voltage against reverse polarity.

Specification:

Input Voltage	230-240 Volts AC 50/60 Hz
Power Rating (Charging)	2.7W 16mA $\lambda = 0.68$
Power Rating (Standby)	1.4W 12mA $\lambda = 0.48$
Insulation between supply & battery	Double Reinforced
Duration	3-hours
Ambient Temp. Ta	0°C to + 50°C
Max Case Temp. Tc	70°C
Max Battery Temperature	55°C
Recharge Period	24 Hours
Battery Type	3.2V 4.8Ah LiFePO4
Charge Current	225mA nominal
Discharge Current	1100mA nominal
Charge Voltage Limit	4.0 Volts
Discharge Voltage Limit	2.5 Volts
Ingress Protection	IP20
Recharge Period	24 Hours
Module Size (L x W x H)	213mm x 30mm x 22.5mm
Module Fixing Centers	207mm
Module Weight	0.11Kg

Battery Details (mm)

Stick 230mm x 24mm x 22mm FC = 220mm

Remote 220mm x 32mm x 34mm

Battery Weight	0.14Kg
Cable Entry Size	0.5mm - 1.5mm

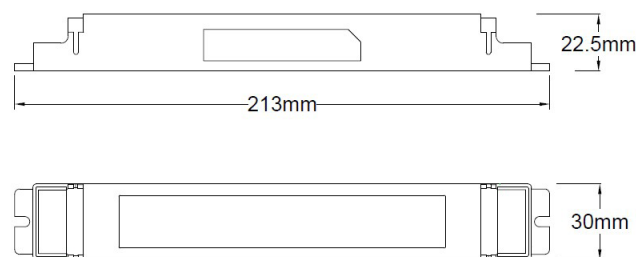

Fixing Centres 207mm

T2N/1S

Rated - 2.3W

Rated - 46-7mA

Voltage Range 50 - 300 Volts

Open Circuit Voltage (U-OUT) = 350 Volts

Warning

Avoid running the LED mains driver and emergency pack without the load connected. Failure to do so may result in damage to the LED array

Important

It is recommended that the module is installed by a competent person ensuring the installation complies with the necessary standards. Liteplan accept no responsibility for injury, damage or loss, which may arise as a result of incorrect installation, operation or maintenance.

The conversion requires an unswitched supply for charging the battery and a switched supply if the unit is being used for maintained operation.

ISOLATE BOTH MAINS SUPPLIES AND DISCONNECT THE BATTERY BEFORE INSTALLATION OR MAINTENANCE.

Installation

When converting a luminaire observe the following points:-

1. Fit the module & battery pack into the existing luminaire ensuring that they will operate within their temperature ratings.
2. If the module & battery pack do not fit integrally, then a remote conversion can be used. Ensure that the interconnecting loom is kept as short as possible.
3. Wire the module & battery into the luminaire as per wiring diagram on Pg2.
4. Ensure that the Permanent Live & Switched Live feeds are connected correctly.
5. Ensure that the DALI pair is connected to the DALI operating system
6. Arrange the wiring to avoid running the 240 Volt cables next to the modules output to the LED to obtain the best EMC results.
7. Requirements for 'F' markings must be observed.
8. Identify clearly the NEW Un-switched supply.
9. Ensure the LED Charge Indicator is clearly visible.
10. If fitted within a metal enclosure, connect earth terminal to metal gear tray for improved EMC.
11. This module is not intended for use in luminaires for high-risk task area lighting.
12. This module is protected against battery polarity reversal.

Installation & Wiring Instructions

T2N/1S High Voltage DALI-2 Self-test Emergency Conversion Kit

PLEASE READ THESE INSTRUCTIONS BEFORE COMMENCING INSTALLATION & LEAVE WITH END USER

General High Voltage
Wiring Diagram

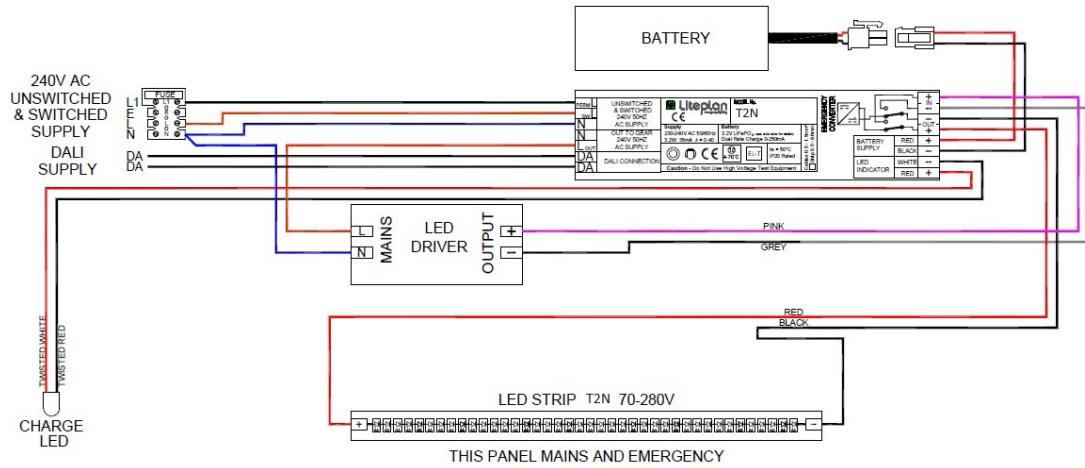

Mains Fed Lamp
Wiring Diagrams

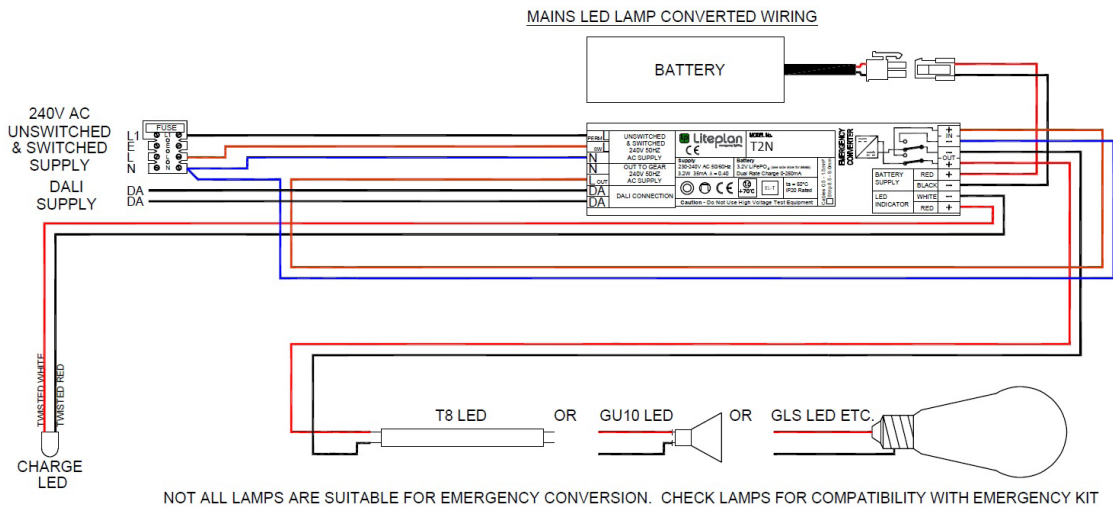

Device Status Indicator:

Green Solid	Battery connected & charging	Red Fast Flash 2 x 0.5 sec On, 2.5 sec Off	Lamp Fault
Green Flash 2.0 sec On, 0.2 sec Off	48h Pre-Commissioning	Red Slow Flash 0.5 sec On, 3.5 sec Off	Battery Fault
Green Flash 0.2 sec On, 2.0 sec Off	Function Test in progress	Red / Green Alternating	Identification Mode
Green Flash 0.2 sec On, 2.0 sec Off	Duration Test in progress	Red & Green Off	In Emergency Mode